

Devices and methods for measuring parameters of RFTES bolometers

© T.M. Kim,¹ A.V. Merenkov,¹ An.B. Ermakov,² L.S. Solomatov,¹ V.I. Chichkov,¹ S.V. Shitov^{1,2}

¹National University of Science and Technology, „MISIS“,
119049 Moscow, Russia

²Kotelnikov Institute of Radio Engineering and Electronics, Russian Academy of Sciences,
125009 Moscow, Russia
e-mail: sergey3e@gmail.com

Received May 12, 2023

Revised May 12, 2023

Accepted May 12, 2023

Several new approaches to the measurement of intrinsic noise and dynamic characteristics of superconducting bolometers based on the RFTES technology are demonstrated. The developed methods were tested with an experimental 550–750 GHz sample at reading frequency of ~ 1.5 GHz at a temperature of 400 mK. The absorption of thin-film resistive coatings on sapphire and quartz substrates was studied, and the emissivity of the experimental heat source was estimated as $\sim 14\%$. A shot noise source based on Al/AlO_x/Al tunnel junction was developed, and the noise temperature of the 1.35–1.6 GHz buffer amplifier referred to the detector output was determined as ~ 20 K. The response time of RFTES with a hafnium film sized $6 \times 2 \times 0.08 \mu\text{m}$ was evaluated as $\sim 3 \mu\text{s}$ via microwave heat modulation at the second resonance at ~ 4.2 GHz; the dynamic range at a modulation frequency of 10 kHz was more than 23 dB. The data obtained made it possible to determine the RFTES sensitivity as $1 \cdot 10^{17} \text{ W}/\sqrt{\text{Hz}} \pm 30\%$, that coincided with the theoretical value up to the measurement error.

Keywords: RFTES, noise equivalent power, response time, dynamic range, blackbody, emissivity, Plancks law, heat modulation, shot noise, electron gas, high-Q resonator, electromagnetic modelling.

DOI: 10.61011/TP.2023.07.56640.117-23

Introduction

Determining the sensitivity, response rate and dynamic range of superconducting terahertz detectors at ultra-low temperatures of the order of 100 mK is a task for which some traditional, time-tested methods and devices are poorly suited. Such detectors are designed, as a rule, to operate with low background radiation values on board space observatories or stratospheric balloons. The sensitivity of detectors is usually characterized by the parameter of Noise Equivalent Power (NEP) which is determined by comparing inherent noise with the noise of a known (calibrated) noise source. The classical source of calibrated noise is a heated black body (BB) — an ideal absorber with a known physical temperature. The absorption and emissivity of the bodies coincide under the condition $hf < k_B T$ due to the principle of reversibility of the field, which is associated with the Planck distribution of the thermodynamic noise spectrum [1]. In practice, electromagnetic radiation absorbers are „gray“, i.e. they do not have ideal absorption, and in some cases their absorption capacity is obviously small and uneven in frequency. In this case, the power received by the detector depends not only on the temperature of the black body and the receiving band, but also on the spectral density of the radiation. Thus, the measurement error may be unacceptably high without taking into account the correction for the frequency-dependent absorption coefficient of the black body.

The traditional method of signal input into the cryostat in the form of a quasi-optical beam is poorly suited

for laboratory studies of ultra-low-temperature detectors, since the absorption of broadband background black body radiation ~ 300 K can overheat the dilution refrigerator, whose refrigerating capacity is $\sim 100 \mu\text{W}$ at 100 mK. For this reason low-intensity sources placed inside the cryostat near the entrance aperture of the detector are used at ultra-low temperatures. Such black body absorbers may look like a porous sponge or a cone-shaped cavity with absorbing walls [2]. The heat source should be heated to ~ 10 K to achieve the power of the test signal $\sim 10^{-14}$ W in the detector band 550–750 GHz, so that the operating frequency range of the sensor would be near or below the cutoff frequency of the Planck spectrum, which corresponds to condition $hf \leq k_B T$. Such heating requires a fairly large electrical power ~ 10 mW, so the source cannot be placed on the same cooling stage with the detector. It is advisable to sink heat to a more powerful stage of the cryostat ~ 1 K, but even in this case, a pulse surge of heat to the stage ~ 1 K can cause noticeable temperature drifts of the cryostat, which last for minutes, and they can be confused with the response of the detector. Usually, a signal modulation is used to suppress the effects caused by thermal drifts, the period of such signal modulation is obviously less than the characteristic drift time, and this modulation is implemented using mechanical or electronic obturators at the detector input. An alternative method is to modulate the temperature of the black body itself. However, at frequencies higher than ~ 1 Hz, such modulation may be difficult due to the low thermal conductivity of the porous absorber, as well as due

to the heat capacity, which is significant even for BB mass ~ 1 g, since rapid heat discharge during the modulation period is inevitable leads to an increase in the average electrical power transmitted to the refrigerating system. A solution can be found by increasing the efficiency of the heat source and the lower the efficiency the more massive the heat source itself (the greater its heat capacity), since the power transmitted to the detector depends only on the temperature and the blackness coefficient. Progress in noise measurements at THz frequencies can be found on the path to creating small-sized black body emitters in combination with broadband emitting antennas [3].

The detector response rate is usually measured using a modulated signal. The maximum speed is usually set by the criterion of reducing the amplitude of the demodulated signal by half. In case of high-speed detectors, the detector response time can be $\sim 10 \mu\text{s}$ or less, which makes it difficult to use even relatively low-inertia thermodynamic sources. Electronically modulated monochromatic signals are used when measuring short response times of ~ 1 ns. For example, there is a known beat method of two monochromatic terahertz oscillators, the radiation of which is supplied from the room [4]. The dilution cryostat for the application of this technique should be provided with an optical or waveguide system that prevents the penetration of infrared radiation ~ 300 K, and expensive terahertz generators should be purchased.

Progress in measuring the response rate of bolometric detectors can be realized on the path of internal heat generation, as discussed in this paper in relation to a bolometric detector built using Radio Frequency Transition Edge Sensor (RFTES) technology [5–7]. The sensitive element of the RFTES bolometer is a hafnium film micro-bridge with an electron gas included simultaneously in the circuit of a planar antenna of the range 550–750 GHz and in the circuit of a superconducting coplanar resonator with a frequency (reading) ~ 1.5 GHz, which allows the use of such a detector in matrices with frequency selection of pixels using FDM (Frequency Division Multiplexing) technology [8]. This paper is devoted to demonstrating new devices and methods for measuring noise and dynamic parameters of a detector built according to the RFTES [9] technology, which, according to the authors, has certain advantages over the already matured TES and MKID [10,11] technologies.

1. Thermodynamic noise source

A „gray body“ was developed to measure the optical response of the RFTES detector, which is a resistive film deposited on a sapphire plate with a diameter of 15 mm, a thickness of 0.5 mm and a mass of less than 0.5 g. The time constant of heating and cooling of the absorber turned out to be close and amounted to ~ 1 s (Fig. 1, *a*); in the experiment, the temperature setting time was longer ~ 15 – 20 s. Fig. 1, *b* shows the calculated dependences of

the optical power on the blackbody temperature, available to a bolometer: for each temperature T_{ph} , the spectrum is integrated in the frequency band 550–750 GHz, taking into account the Planck's cut-off. Two values of the emissivity A were used in calculations: for a completely black body, $A = 1$ was used (at all frequencies), and for an experimental absorber, the spectrum was adjusted taking into account the frequency-dependent $A(f)$.

The estimated value of the emissivity ~ 0.42 was used in paper [9]; it neglects the frequency variation and transparency of the film. A comparison of the calculated power at the input of the RFTES bolometer and the measured increment at the output allowed obtaining the transmission coefficient and additional NEP $\approx 3 \cdot 10^{-17} \text{ W}/\sqrt{\text{Hz}}$, which turned out to be only 3 times higher than the theoretical prediction. This was the motivation for a separate study devoted to clarify the characteristics of the source.

Determining the emissivity of a film absorber at terahertz frequencies looks like a very difficult experimental task, and it was decided to limit the calculation of the absorption coefficient using modern methods of electromagnetic modeling. An electromagnetic model was developed using the AWRDE Microwave Office [12] environment this, which allows the formation of a flat incident wave. The wave properties in a rectangular single-mode waveguide with metal walls were taken as a basic model. It is known that a plane wave propagating in a limited section of such a waveguide coincides with the result of interference of two plane waves incident at a slight angle to the waveguide axis, i.e. to the normal of the film installed across the waveguide axis. It is reasonable to assume that the reflection from a film mounted in a rectangular waveguide should not differ from the reflection of a linear superposition of two plane waves in free space. The virtual measuring system is arranged as follows. An identical emitter and receiver were designed in the form of two pairs of half-wave vibrators from an ideal conductor at the two opposite ends of a short-ended rectangular waveguide of section $400 \times 240 \mu\text{m}$ with perfectly conducting walls, as shown in Fig. 2, *a*. The installation planes of the vibrators shown in Fig. 2, *a* are located at a distance of about $80 \mu\text{m}$ from the shorted ends of the waveguide (top and bottom), which act as a counter-reflector. The system is configured to transmit power in the frequency band of 550–750 GHz with losses of no more than 1 dB at the edges of the range.

This model made it possible to determine the reflection and wave transmission coefficient for a thin resistive film with different resistance on substrates of sapphire ($\epsilon \approx 10$) and quartz ($\epsilon \approx 4$), while aiming to refine the parameters of the experimental source. The resistance of the film per square varied in the range $\rho = 25$ – $1000 \Omega/\square$, and the thickness of the substrate in the range 50 – $500 \mu\text{m}$, which allowed determining the optimal value of the surface resistance, which was $\rho = 200 \Omega/\square$. Fig. 2, *b–e* shows the case of an experimental film $\rho = 1000 \Omega/\square$, the case of a two-sided coating of the substrate with a resistive film

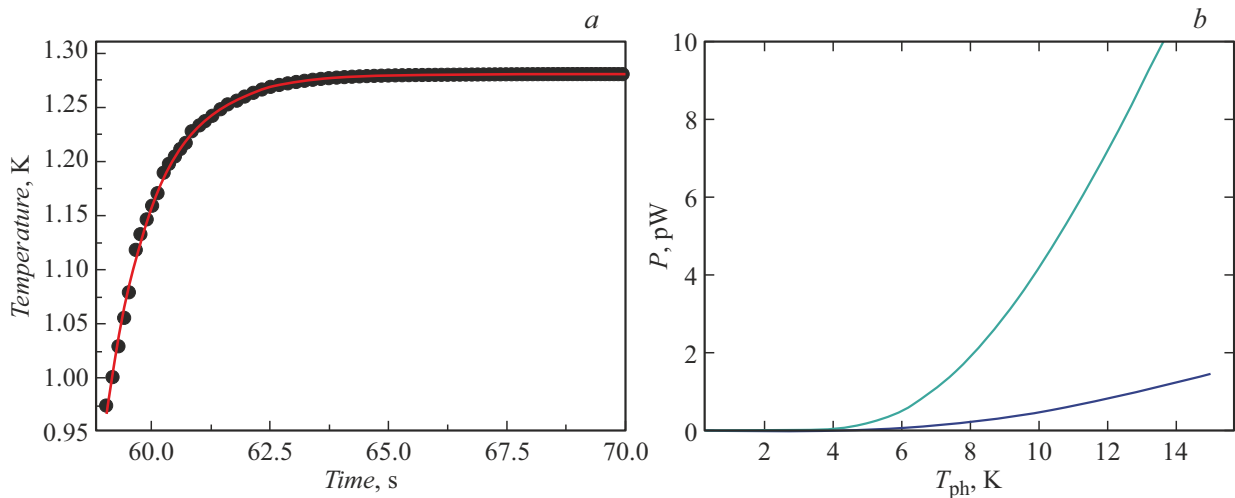

Figure 1. Direct current heating of the film emitter. *a* — experimental dynamics of direct current heating of a sapphire plate 0.2 mA (points). Calculated heating dynamics with a time constant of 0.8 s (solid curve); *b* — dependence of the maximum possible power value received by the detector in the range 550–750 GHz, on the temperature of the absorber, calculated for two values of the blackness coefficient: $A = 1$ (upper curve) and $A \approx 0.14$ (lower curve).

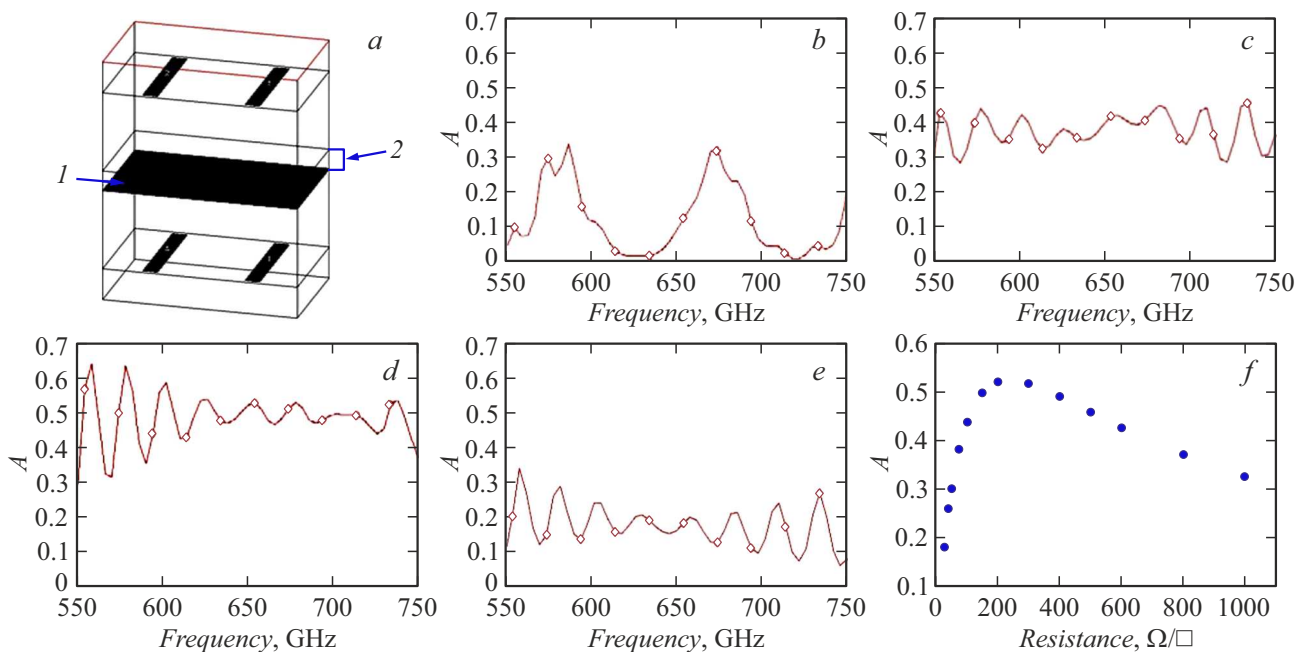

Figure 2. Results of electromagnetic analysis of the absorption coefficient A of a thin resistive film on a dielectric substrate from frequency. *a* — electromagnetic model of a muffled segment of a rectangular waveguide with receiving and transmitting pairs of dipoles. All external faces of the parallelepiped — are thin perfectly conductive walls; the axis of wave propagation is directed vertically: *1* — absorber film, *2* — dielectric substrate; *b* — film absorption coefficient $1000 \Omega/\square$ on a sapphire substrate thickness $500 \mu\text{m}$ (experimental case); *c* — film $200 \Omega/\square$ applied on both sides of a sapphire substrate $500 \mu\text{m}$; *d* — „suspended“ film $200 \Omega/\square$; *e* — film $200 \Omega/\square$ on a quartz substrate with a thickness of $50 \mu\text{m}$; *f* — summary absorption data for „suspended“ film with different values of surface resistance Ω/\square (average values for range 550–750 GHz).

$\rho = 200 \Omega/\square$, the ideal case of a suspended film (without a substrate), as well as a variant of a thin quartz substrates. Fig. 2, *f* summarizes the absorption data of a suspended film of different resistance.

Electrodynamic modeling showed that the emissivity of the absorber can reach the highest value of 50% at

$\rho \approx 200 \Omega/\square$ only for suspended film. Full absorption is impossible due to the fact that the ultrathin film radiates into both half-spaces, i.e. it is translucent. For experimental resistance $\sim 1000 \Omega/\square$ on a 0.5 mm thick sapphire substrate, the emissivity is reduced to several percent, demonstrating serious frequency ripples caused by

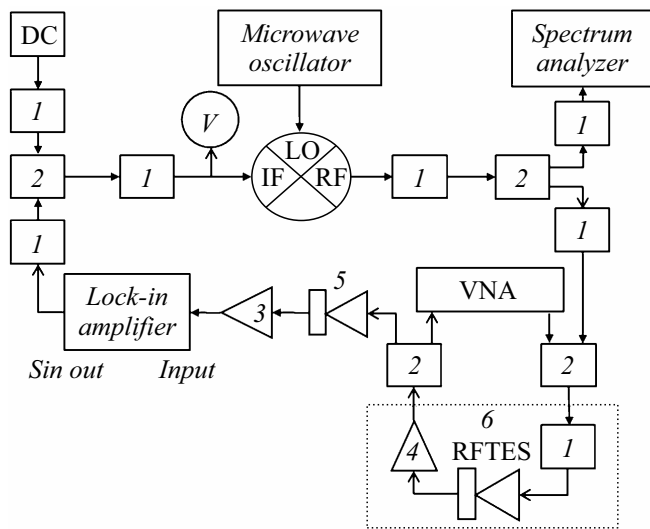

Figure 3. Scheme of an experimental setup for measuring the dynamic characteristics of an RFTES bolometer: 1 — decoupling attenuators 3 or 6 dB, 2 — adders and power dividers, 3 — low-noise low-frequency amplifier, 4 — cooled low-noise microwave amplifier, 5 — demodulator, 6 — dissolution cryostat DR200 „Triton“ from „Oxford Instruments“.

interference of direct and reflected waves inside the sapphire substrate. The integral emissivity coefficient of such an emitter in the frequency range 550–750 GHz is only 14% of the ideal black body with the same temperature, as shown in Fig. 1, *b* (lower curve). The double-sided coating of the same substrate (Fig. 2, *c*) allows improving the emissivity to $A \approx 0.4$ and avoiding frequency ripple, which can be considered a good emitter option for future experiments. The use of a relatively thin substrate $\varepsilon \approx 4$ (quartz 50 μm) is less effective.

An important result of the study of the film-based black body is that the thermodynamic power used in calculating the sensitivity of the detector in [9] was overestimated by 3 times, and the value of NEP turned out to be overestimated (i.e. assumed worse). This is a good reason for correcting the response data of the experimental bolometer. At this stage of the study, it can be concluded that, based on the physical parameters of the hafnium film used and the operating temperature the obtained experimentally $\text{NEP} \approx 1 \cdot 10^{-17} \text{ W}/\sqrt{\text{Hz}}$ coincides with the NEP calculated by HEDD (Hot Electron Direct Detector) up to the measurement error ($\sim 1 \text{ dB}$ or $\sim 30\%$) [13].

2. Buffer amplifier noise

All currently known terahertz signal sensors are signal converters to a lower frequency, at which further signal processing is possible using traditional electronic devices, amplifiers, digitizers, etc. The power conversion factor of such sensors, as a rule, does not exceed unity. This means that the noise of the amplifying path, referred to

the sensor input, can significantly reduce the sensitivity of the entire device. If a semiconductor amplifier is used that produces relatively much heat ($\sim 10 \text{ mW}$), it is usually not placed near the sensor, but connected to the sensor with a sufficiently long heat-insulating coaxial cable, which increases the noise temperature at the input of such a circuit.

The experiment used a SIS junction with the structure Al/AIO_x/Al at a temperature of 30–50 mK, as it was proposed earlier in the paper [3]. It is known that the noise power generated by the SIS junction weakly depends on the physical temperature, and the power dissipated can be as low as $\sim 0.1 \mu\text{W}$. It was found that the noise temperature measured at the input connector of the cable that leads to the amplifier installed on the cryostat stage 3 K is $\sim 20 \text{ K}$, and not 5–10 K, as previously estimated, based on the specification of the used amplifier.

Such discrepancies seriously affect the assessment of the conformity of experimental samples with the physical and mathematical models used. At the same time, the contribution of amplifier noise to the measured noise of the bolometric receiver as a whole may be underestimated, which leads to incorrect estimates of the noise of the bolometer itself. Since the sensitivity of the detector [9] is largely a calculated parameter based on the calibration of blackbody noise, the detected excess noise of the amplifier shifts the confidence interval of the NEP values of the sensor itself towards smaller values.

3. Response rate and dynamic range

Recently, new solutions for rapid modulation of a thermodynamic signal source have been proposed and elaborated in detail, suitable for use inside a cryostat at temperatures of $\sim 100 \text{ mK}$, including a terahertz noise numerical study based on planar lens antennas with internal temperature calibration based on the shot noise of a superconducting tunnel junction [3]. The modulation rate of such a terahertz source with a thermodynamic temperature of the order of $\sim 10 \text{ K}$ is determined by the thermal relaxation time of the microbridge and can be $< 10 \mu\text{s}$ for a niobium film on sapphire. At present, an experiment on direct modulation of terahertz noise is in preparation stage, so we used a new method for measuring based on modulation of the internal heating of the detector using an amplitude-modulated signal at a frequency that does not coincide with the reading frequency (resonator frequency). It should be noted here that at the resonator frequency $\sim 1.5 \text{ GHz}$ and, consequently, at higher frequencies, there is a smooth heating of the bolometric bridge, which allows setting the operating temperature to the optimal value dR/dT . It is reasonable to assume that when heated by current at the frequency of the second resonator mode, which can be called the second resonator transparency band, the thermal relaxation rate of the electronic subsystem of the bridge will not change. If the frequencies of the second resonator mode are outside the operating frequency band of the buffer

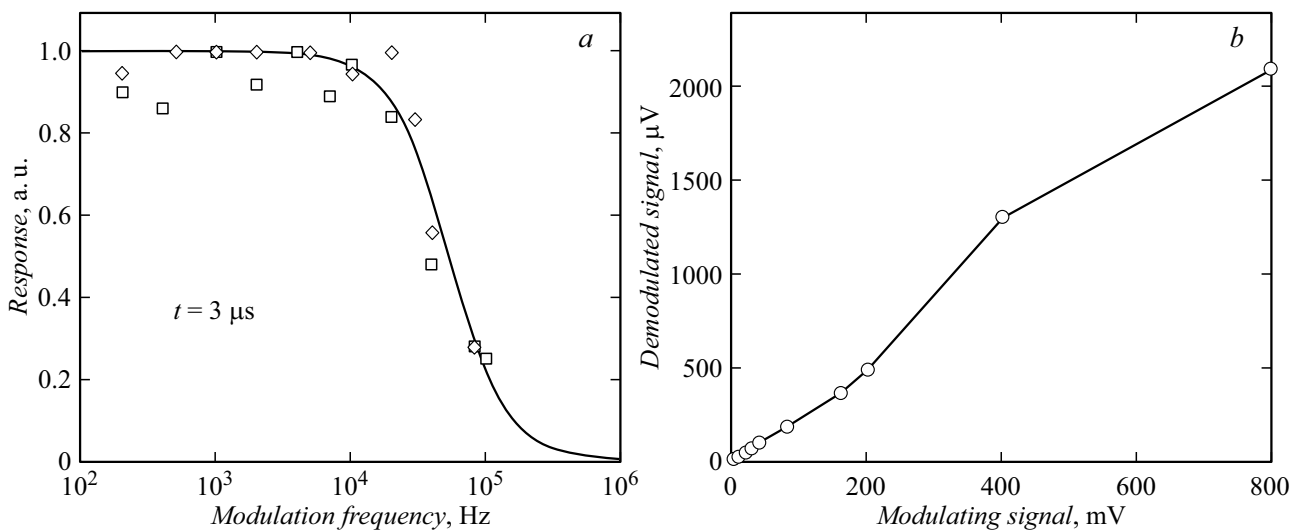

Figure 4. Dynamic characteristics of the RFTES bolometer. *a* — experimental data on the dependence of the normalized response amplitude on the modulation frequency (points) and the theoretical dependence for $\tau = 3 \mu\text{s}$; *b* — the dependence of the demodulation amplitude at the input of the phase detector on the voltage of the modulator (points). Solid line is the linear interpolation between experimental values.

amplifier, 1.35–1.6 GHz, then the modulation of the carrier frequency ~ 4.2 GHz can be registered only due to the heating of the electronic subsystem.

The scheme of the experimental setup for measuring the response rate and dynamic range of the bolometer is shown in Fig. 3. The amplitude-modulated signal is formed using a balanced mixer ZX06-U432H-S+ from „Mini Circuit“. The carrier frequency ~ 4.2 GHz (+17 dBm) is supplied as a heterodyne to the LO (Local Oscillator) connector of the mixer from the „Agilent“ generator E8257D. Carrier modulation is set using the IF (Intermediate Frequency) connector of the mixer from the reference generator of the phase detector (hereinafter — PD) SR830 from „Stanford Research“. The modulated signal is taken from the RF (Radio Frequency) output of the mixer and divided in half for the N9030A signal analyzer (Agilent Technologies), which visualizes the spectrum, and power coming to the detector. The second half of the modulated signal is summed with the biasing power at the frequency ~ 1.5 GHz, supplied from the vector network analyzer N5242B from „Keysight“. The resulting composite signal is fed inside the cryostat to the studied RFTES detector via a common coaxial cable.

The signal from the output of the RFTES detector enters the cooled amplifier and is then divided equally between the network analyzer and the demodulator (video detector); the amplitude of the demodulated signal is recorded PD. The modulation frequency varied in the range from 100 Hz to 100 kHz in the experiment. The obtained dependence of the amplitude of the demodulated signal on the modulation frequency of the signal at the second harmonic of the resonator is shown in Fig. 4, *a*. The response can be considered independent of the modulation frequency below 16 kHz according to these data. The response is reduced to 50% near the frequency of 20 kHz, which allows

estimating the relaxation time of the device $\sim 3 \mu\text{s}$. The rate of electron-electron interaction in a hafnium film at a temperature of ~ 400 mK, calculated by the method [14], is ~ 15 ns, and the cooling rate determined by the electron-phonon relaxation time is $\sim 10 \mu\text{s}$, which is close to the reaction time of the resonator itself with the band ~ 50 kHz in terms of the order of magnitude. Thus, we can conclude that the characteristic times of the bridge and the resonator are consistent with each other, and the system is close to optimum.

The linearity of the RFTES bolometer response was evaluated at a fixed modulation frequency ~ 10 kHz. An almost linear dependence of the amplitude of the demodulated response on the modulation voltage in the range of 4–800 mV (more than 23 dB) was obtained. Experimental data on the dependence of the response amplitude on the voltage/modulation depth are shown in Fig. 4, *b*. The power of heating of the bridge at a frequency of ~ 1.5 GHz was ~ 0.3 pW, which, taking into account the negative thermal feedback, determines the absolute maximum of the input signal [8,10]. As the spectral analysis showed, a small „hump“ on the dependence shown on Fig. 4, *b* is a „spoor response“ associated with the leakage of parasitic harmonics that associated with imperfection of the balanced mixer.

Conclusion

The developed instruments and measurement methods were successfully used to determine the key parameters of an ultra-low temperature RFTES bolometer based on hafnium film: NEP, response time and dynamic range. The study of the RFTES detector required the improvement of the traditional components of the measuring system and

the methods associated with its calibrations. An original study of the emissivity of a heat source based on a dielectric substrate with a resistive coating was performed, which is not described in the literature, but fundamentally affects the NEP calibration. The measurement of the noise introduced into the system by the amplification channel was measured not via physical heating of the matched load, but using the shot noise of a superconducting tunnel junction, which can operate at ultra-low temperatures. The search for alternative ways to generate a rapidly alternating thermal signal led to the development of an original method of injection of modulated power at one of the higher resonator modes. Thus, the work has methodological, scientific and practical value, which makes it possible to extend its results to a wider range of detectors. The results obtained confirm the prospects of new detectors with microwave reading of the nonlinear impedance of the electron gas, and also demonstrate new approaches to the development of traditional metrological methods.

Funding

The study was supported by the RFBR project № 20-37-90094 „Aspirants“ and the project of NUST MISIS „Quantum Internet“ (grant № K2-2022-029) as part of Strategic Academic Leadership Program „Prioritet-2030“.

Conflict of interest

The authors declare that they have no conflict of interest.

References

- [1] T.S. Kuhn. *Black-Body Theory and the Quantum Discontinuity*, 1894–1912. — 2nd ed. (Chicago: University of Chicago Press, 1987)
- [2] A.V. Uvarov, S.V. Shitov, A.N. Vystavkin. *Meas. Tech.*, **53** (9), 1047 (2010). DOI:10.1007/s11018-010-9617-4
- [3] T.M. Kim, S.V. Shitov. *Tech. Phys. Lett.*, **48** (15), 54 (2022). DOI: 10.61011/TP.2023.07.56640.117-23
- [4] E.M. Gershenson, M.E. Gershenson, G.N. Gol'tsman, A.M. Lyul'kin, A.D. Sernenov, A.V. Sergeev. *JETP*, **97**, 901 (1990).
- [5] S.V. Shitov. *Tech. Phys. Lett.*, **37**, 932 (2011). <http://journals.ioffe.ru/pjtf/2011/19/p88-94.pdf>
- [6] A.V. Merenkov, V.I. Chichkov, A.B. Ermakov, A.V. Ustinov, S.V. Shitov. *IEEE Trans. Appl. Supercond.*, **28**, 7 (2018). DOI:10.1109/TASC.2018.2827981
- [7] A.V. Merenkov, S.V. Shitov, V.I. Chichkov, A.B. Ermakov, T.M. Kim, A.V. Ustinov. *Tech. Phys. Lett.*, **44** (7), 581 (2018). DOI:10.1134/S106378501807012X
- [8] P.A.J. de Korte, J. Beyer, S. Deiker, G.C. Hilton, K.D. Irwin, M. MacIntosh, S.W. Nam, C.D. Reintsema, L.R. Vale. *Rev. Sci. Instrum.* **74**, 3087 (2003). DOI: 10.1063/1.1593809
- [9] A.V. Merenkov, T.M. Kim, V.I. Chichkov, S.V. Kalinkin, S.V. Shitov. *FTT*, **64** (10), 1404 (2022) (in Russian). DOI:10.21883/FTT.2022.10.53081.50HH
- [10] A.T. Lee, P.L. Richards, S.W. Nam, B. Cabrera, K. D. Irwin. *Appl. Phys. Lett.*, **69** (12), 1801–1803 (1996). DOI: 10.1063/1.117491
- [11] D.K. Day, H.G. LeDuc, B.A. Mazin, A. Vayonakis, J. Zmuidzinas. *Nature*, **425**, 817 (2003). DOI: 10.1038/nature02037
- [12] Cadence AWR Microwave Office. Electronic source. Available at: <https://www.flowcad.com/en/awr-microwave-office.htm>
- [13] B.S. Karasik, R. Cantor. *Appl. Phys. Lett.*, **98**, 193503 (2011). DOI: 10.1063/1.3589367
- [14] B.L. Altshuler, A.G. Aronov. *Modern Problems. Condens. Matter. Sci.*, **10**, 1 (1985). DOI: 10.1016/B978-0-444-86916-6.50007-7

Translated by A.Akhtyamov