

Review and classification of space-time vectors of discrete states of a seven-phase converter

© V.M. Tereshkin, D.A. Grishin, S.P. Balandin, V.V. Tereshkin

Ufa State Aviation Technical University, Ufa, Russia
 e-mail: tvn53@mail.ru

Received April 29, 2021

Revised July 27, 2021

Accepted July 30, 2021

The subject of the research is the control algorithms for a seven-phase converter that implement space-vector voltage modulation of a seven-phase motor as an alternative to a three-phase engine in modern electric traction. The study used elements of set theory, combinatorics, Fourier series expansion and vector analysis. Checking research results was implemented on a special stand for experimental studies of spatial vector voltage modulation of a seven-phase motor.

Keywords: Power of the mathematical set of logical states of a seven-phase converter, vector space of generalized vectors of discrete state, combinations of generalized vectors of discrete voltage states of a seven-phase motor

DOI: 10.21883/TP.2022.01.52541.131-21

Introduction

Classical three-phase rotary-field motors (asynchronous and synchronous) have always been used in electric traction. However, state-of-the-art power electronics, converter equipment, microcontrollers, and information technology allow one to generate symmetrical multiphase voltage with an arbitrary number of phases, and a multiphase motor may be constructed based on the magnetic system of a three-phase rotary-field machine with a slightly reengineered operating winding. Therefore, electric traction based on a multiphase motor (with more than three phases) is technically feasible and may find application if its advantages over an electric drive based on a three-phase rotary-field motor are proven incontestable.

Vehicle manufacturers currently express considerable interest in research into electric traction [1]. Hybrid propulsion plants with electric traction are currently being developed for aircraft, traction electric motors compete favorably with thermal engines constructed for small airplanes, and electric cars are being used more and more frequently in highway transportation. A considerable number of papers focused on various aspects of vector control of three-phase rotary-field motors have already been published [2-4]. Electric drives based on, e.g., a four-phase asynchronous motor with vector control have also been constructed [5].

It has been demonstrated that the rated phase current and the level of vibrations of electromagnetic origin decrease as the number of phases of a rotary-field motor increases. In addition, an increased number of phases may have a positive effect on the level of reliability of a motor [6-8]. Thus, the construction of an electric drive based on a multiphase motor is one of the current lines of development of electric traction.

A considerable amount of work on the design of an electric drive based on a multiphase motor is spent on the control system (algorithms implementing space-vector modulation, vector control regulators, etc.).

The space-vector pulse-width modulation (SVPWM) technique is used in generating symmetrical multiphase voltage by a converter and connecting a multiphase motor to it. The present study is aimed at examining the operating algorithms of a seven-phase converter that implements space-vector modulation of a seven-phase motor.

1. Formulation of the problem

Figure 1 shows the functional diagram of a seven-phase bridge converter connected to a symmetrical seven-phase star-connected winding (ABCDEFG) of a rotary-field motor. The converter is connected to a power supply with voltage U . Keys of the anode and cathode groups are denoted with even and odd numbers, respectively. The input converter voltage is assumed to be equal to unity, $U = 1$.

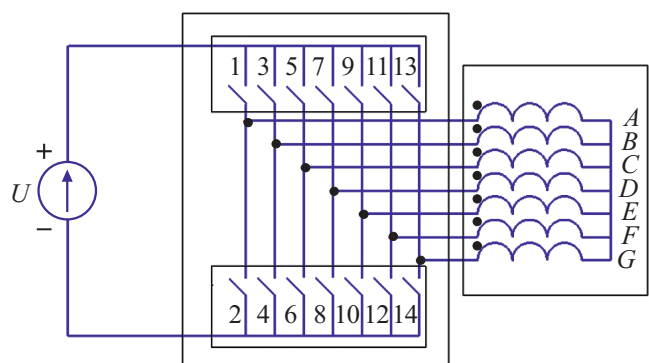

Figure 1. Functional diagram of a seven-phase system.

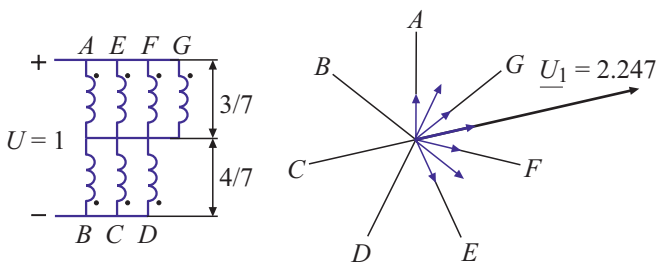

Figure 2. Equivalent circuit diagram and vector space of voltages of a seven-phase winding at logical state 1000111 of the converter.

The seven-phase converter has $2^7 = 128$ logical states. If the upper key of a converter arm is closed and the lower one is open, the logical state of the converter arm is „1“. If the upper key of the converter arm is open and the lower one is closed, the logical state of the converter arm is „0“. For example, logical state 1000000 corresponds to closed key 1 (with key 2 being open) and open keys 3, 5, 7, 9 (with keys 4, 6, 8, 10 being closed).

Logical states 0000000 and 1111111 correspond to the closing of phases of the seven-phase winding by the lower and upper keys, respectively. Thus, the seven-phase converter produces $128 - 2 = 126$ active discrete states of the system (with energy consumed by the motor) and two null states.

If we use mathematical terms, the following description is valid: each logical state of the converter is an „invariant“, and the entire array of „invariants“ (all possible logical states of the converter) is a mathematical set with a cardinality of 128.

For comparison, the cardinality of the mathematical set of logical states of three-, four-, five-, six-, and, e.g., eleven-phase converters is 8, 16, 32, 64, and 2048, respectively. Thus, the cardinality of the mathematical set of logical states of the converter increases by a factor of 2 with each additional phase.

All 126 active logical states of the seven-phase converter (each logic „invariant“) form unique resultant space-time vectors of voltage of the seven-phase winding („invariant“ of the vector space). Each vector of this kind is a vector of discrete states. The process of formation of vectors of discrete voltage states is commonly referred to as space-vector modulation.

Each of the two null logical states of the converter may form a set of resultant space-time vectors (depending on the previous history of switching). This set of vectors is referred to as null vectors.

When symmetrical m -phase voltage is generated, space-time vectors of discrete states are modulated (implemented). The generation of symmetrical m -phase voltage with even and odd numbers of phases requires m -step and $2m$ -step switching, respectively.

The seven-phase symmetrical voltage is generated through 14-step switching. The set of 126 logical states may be divided into 9 subsets of 14 states ($126/14 = 9$). Each

of the 9 subsets of logical states forms a vector space of resultant space-time voltage vectors consisting of 14 vectors of discrete states. Each vector space corresponds to the seven-phase symmetrical voltage with a certain shape of phase voltage.

Figure 2 shows the equivalent circuit diagram of the converter load and illustrates the process of formation of the resultant vector (discrete states) in the seven-phase winding space at logical state 1000111 of the converter. The construction of the resultant space-time vector of voltage of discrete states is illustrated.

2. Results of experimental studies

Figure 3 presents the experimental data (the upper part of the oscilloscope record is the shape of phase voltage, and the lower part is the ripple of the winding common-point potential with respect to the converter „zero“) and the corresponding vector spaces of generalized space-time vectors of discrete states for the seven-phase winding. The results of examination of, e.g., versions 1 and 2 were detailed in [9].

The magnitudes of generalized space-time vectors of discrete states are denoted in Fig. 3. These magnitudes correspond to the first-harmonic amplitudes of sine curves of the phase voltage of different shapes. The vector space of version 1 has the maximum magnitude of vector of discrete states (0.642). The expansion into a Fourier series revealed that the first-harmonic amplitude of the sine curve of the phase voltage of this shape is 0.637. The vector with a magnitude of 0.637 is a vector of continuous rotation.

3. Logical states of the seven-phase converter

Logical states of the converter forming the vector spaces of resultant (generalized) vectors of discrete states are as follows:

Version 1

1000111, 1000011, 1100011, 1100001, 1110001, 1110000, 1111000, 0111000, 0111100, 0011100, 0011110, 0001110, 0001111, 0000111.

14 switchings in a period.

Version 2

1010100, 1011010, 0101010, 0101101, 0010101, 1010110, 1001010, 0101011, 0100101, 1010101, 1010010, 1101010, 0101001, 0110101.

$14 \cdot 3 = 42$ switchings in a period.

Version 3

0000011, 1100111, 1000001, 1110011, 1100000, 1111001, 0110000, 1111100, 0011000, 0111110, 0001100, 0011111, 0000110, 1001111.

$14 \cdot 3 = 42$ switchings in a period.

Version 4

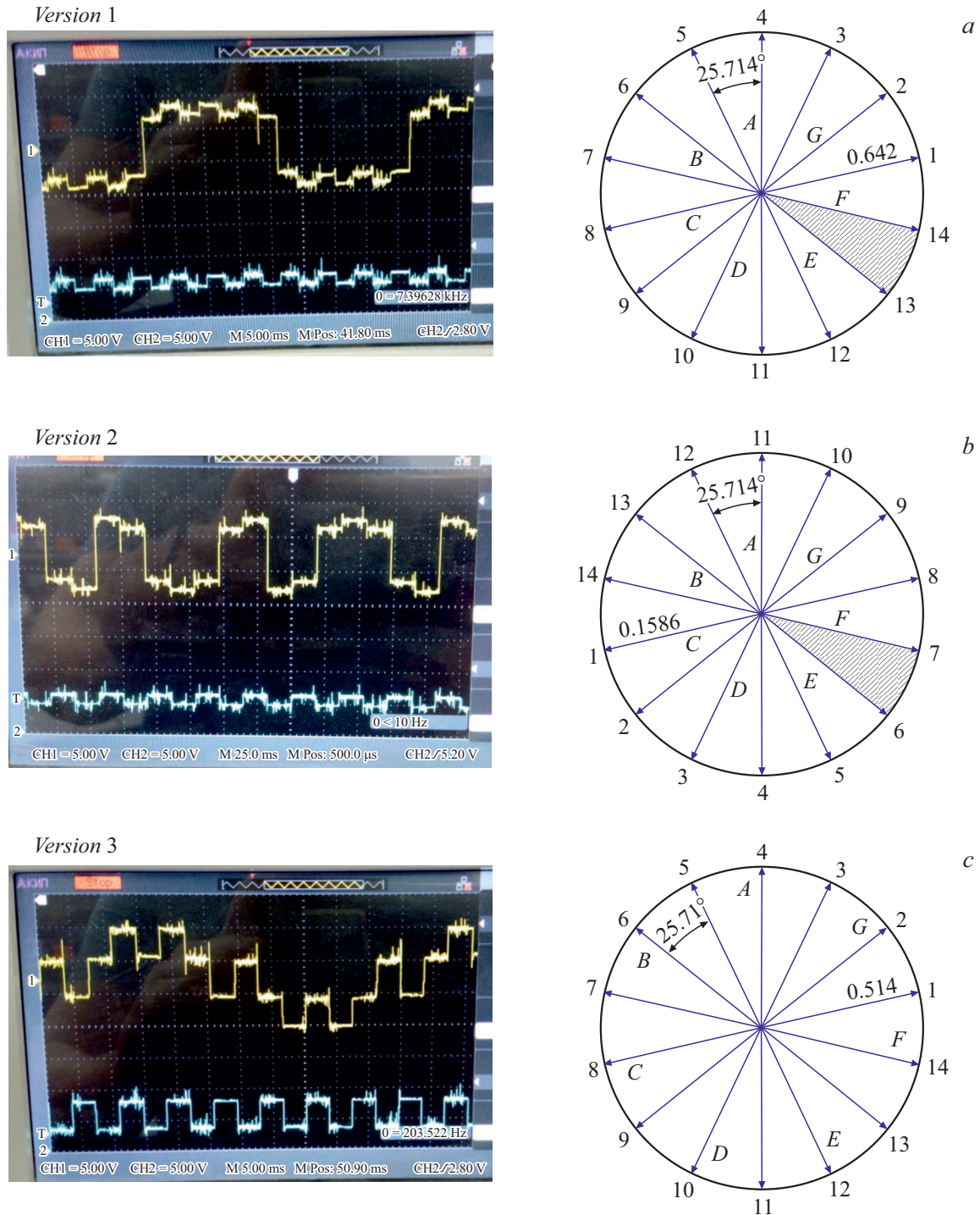

Figure 3. Shapes of phase voltage, ripple of the winding common-point potential with respect to the converter „zero“ and the corresponding vector spaces of generalized vectors of discrete states.

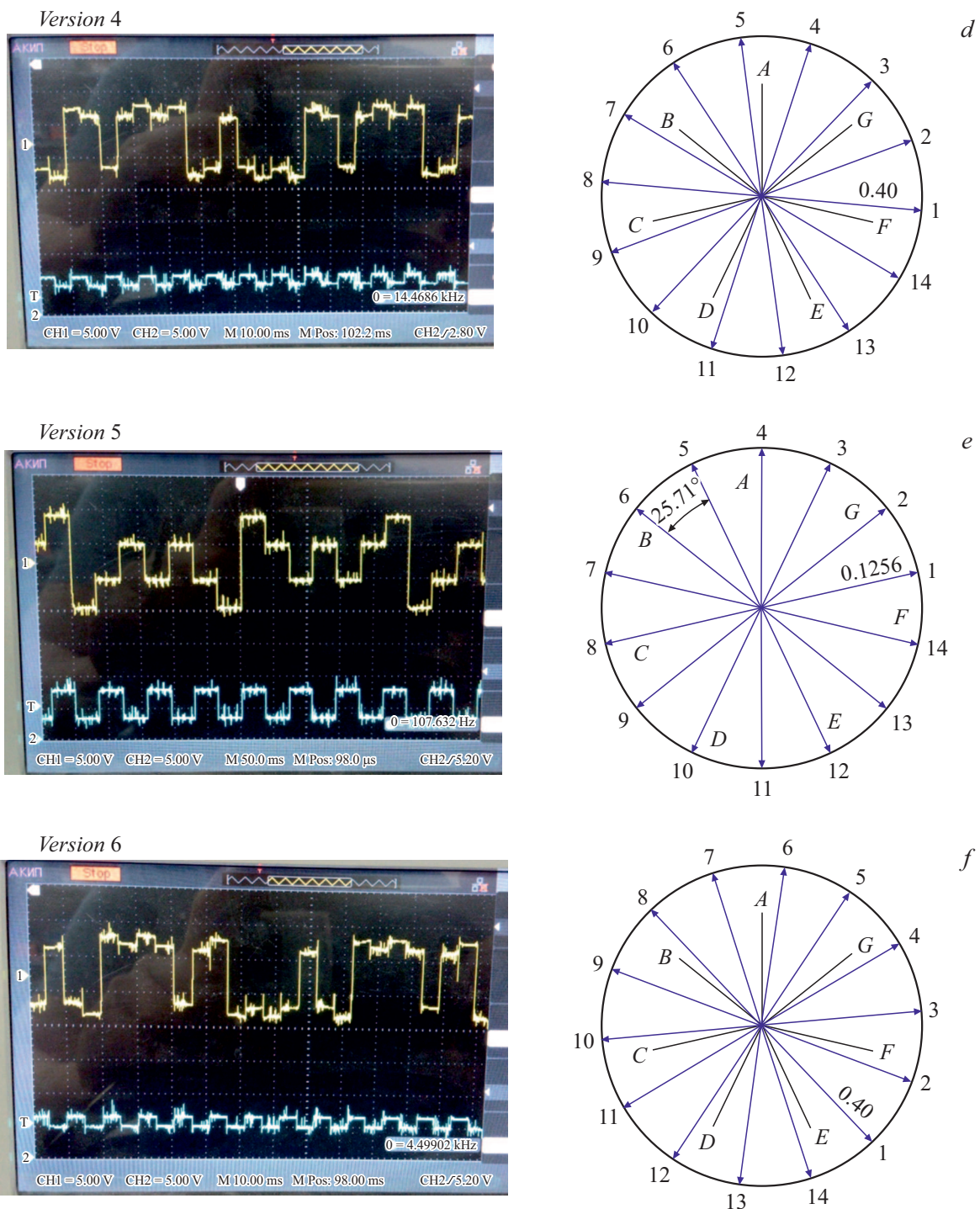

Fig. 3 (contd.).

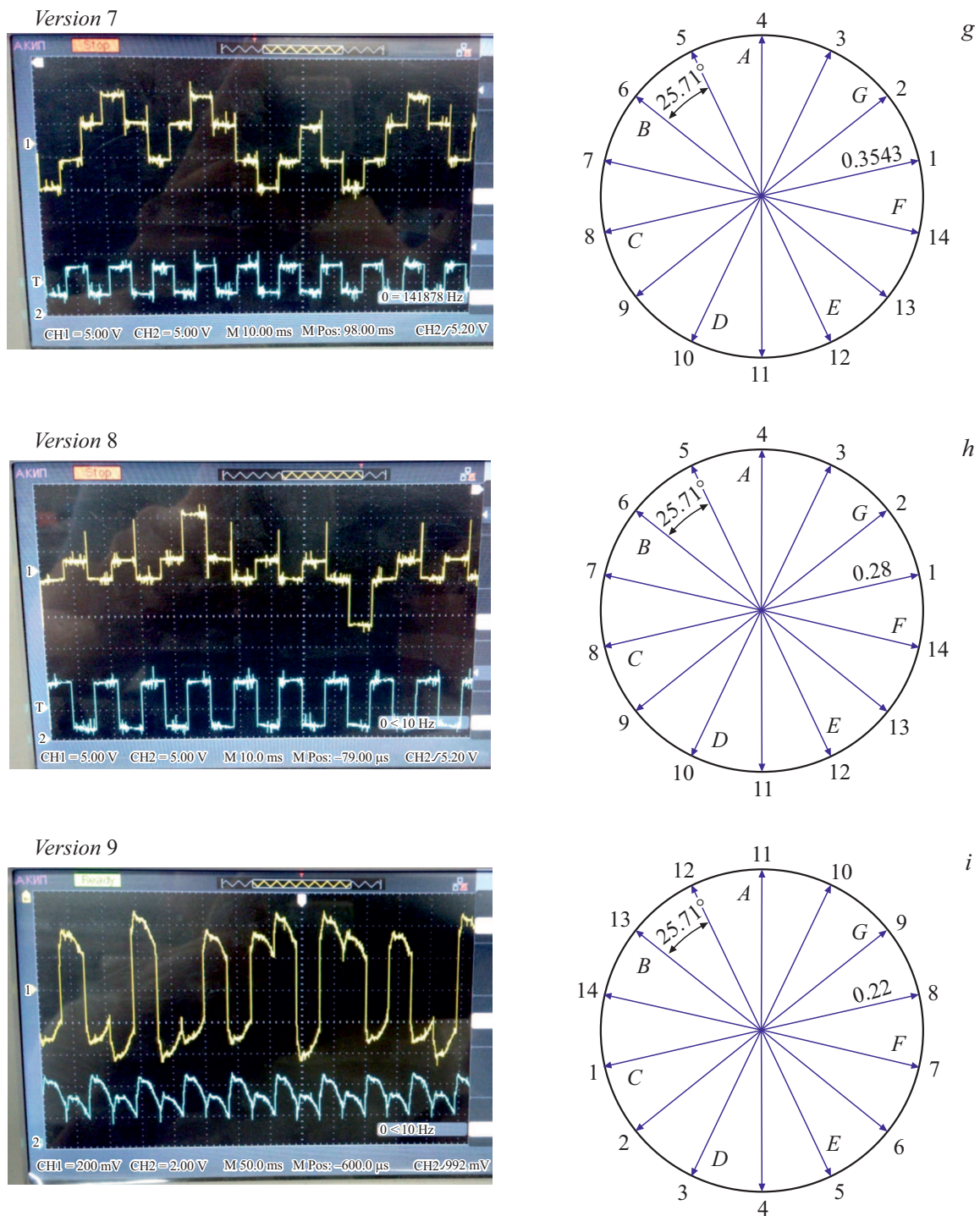

Fig. 3 (contd.).

1000110, 1001011, 0100011, 1100101, 1010001, 1110010,
1101000, 0111001, 0110100, 1011100, 0011010, 0101110,
0001101, 0010111.

$14 \cdot 3 = 42$ switchings in a period.

Version 5

1000100, 1011011, 0100010, 1101101, 0010001, 1110110,
1001000, 0111011, 0100100, 1011101, 0010010, 1101110,
0001001, 0110111.

$14 \cdot 5 = 70$ switchings in a period.

Version 6

1001110, 0001011, 0100111, 1000101, 1010011, 1100010,
1101001, 0110001, 1110100, 1011000, 0111010, 0101100,
0011101, 0010110.

$14 \cdot 3 = 42$ switchings in a period.

Version 7

1010111, 1000010, 1101011, 0100001, 1110101, 1010000,
1111010, 0101000, 0111101, 0010100, 1011110, 0001010,
0101111, 0000101.

$14 \cdot 3 = 42$ switchings in a period.

Version 8

1101111, 0000001, 1110111, 1000000, 1111011, 0100000,
1111101, 0010000, 1111110, 0001000, 0111111, 0000100,
1011111, 0000010.

$14 \cdot 5 = 70$ switchings in a period.

Version 9

1101100, 0011001, 0110110, 1001100, 0011011, 0100110,
1001101, 0010011, 1100110, 1001001, 0110011, 1100100,
1011001, 0110010.

$14 \cdot 5 = 70$ switchings in a period.

4. Examination of combinations of the vector space

Each of the nine versions features 6 combinations of logical states of the converter residing in a common vector space. The possible combinations or sequences of discrete states (or control algorithms) forming vector spaces are as follows:

Combination 1 (+1)

1, 2, 3, 4, 5, 6, 7, 8, 9, 10, 11, 12, 13, 14... ,
1000111, 1000011, 1100011, 1100001, 1110001, 1110000,
1111000, 0111000, 0111100, 0011100, 0011110, 0001110,
0001111, 0000111.

14 switchings in a period.

Combination 2 (+2)

1, 3, 5, 7, 9, 11, 13... ,
1000111, 1100011, 1110001, 1111000, 0111100, 0011110,
0001111.

$14 \cdot 2 = 28$ switchings in a period.

Combination 3 (+3)

1, 4, 7, 10, 13, 2, 5, 8, 11, 14, 3, 6, 9, 12... ,
1000111, 1100001, 1111000, 0011100, 0001111, 1000011,
1110001, 0111000, 0011110, 0000111, 1100011, 1110000,
0111100, 0001110.

$14 \cdot 3 = 42$ switchings in a period.

Combination 4 (+4)

1, 5, 9, 13, 3, 7, 11... ,

1000111, 1110001, 0111100, 0001111, 1100011, 1111000,
0011110.

$14 \cdot 4 = 56$ switchings in a period.

Combination 5 (+5)

1, 6, 11, 2, 7, 12, 3, 8, 13, 4, 9, 14, 5, 10... ,
1000111, 1110000, 0011110, 1000011, 1111000, 0001110,
1100011, 0111000, 0001111, 1100001, 0111100, 0000111,
1110001, 0011100.

$14 \cdot 5 = 70$ switchings in a period.

Combination 6 (+6)

1, 7, 13, 5, 11, 3, 9... ,
1000111, 1111000, 0001111, 1110001, 0011110, 1100011,
0111100.

$14 \cdot 6 = 84$ switchings in a period.

In the general case, the number of combinations is $(m-1)$, where m is an odd number of phases. For example, a winding with $m = 11$ phases features ten combinations.

The experimental phase voltage shapes corresponding to different combinations are shown in Fig. 4. Converter frequency f is 1.6 Hz.

The experimental data were obtained using a test stand constructed for the examination of algorithms of space-vector modulation of multiphase machines (from 3 to 8 phases). The photographic image of the stand is presented in Fig. 5. The stand was described in detail in [10].

5. Discussion

The cardinality of the mathematical set of logical states of the seven-phase converter, which is equal to 126, allows one to construct a large number of control algorithms implementing space-vector modulation of the seven-phase winding and generating symmetrical seven-phase voltage.

Nine algorithms for generation of symmetrical seven-phase voltage with nine phase voltage shapes (with different spectral compositions of the phase voltage) are available. The possible voltage shapes are shown in Fig. 3. It can be seen that the most efficient sample of logical states is the sample of version 1. The sample of version 1 makes it possible to form space-time vectors of discrete voltage states with the maximum magnitude.

5.1. Combination 1 of the sample of version 1

With 14-step switching in the following sequence of logical states: 1000111, 1000011, 1100011, 1100001, 1110001, 1110000, 1111000, 0111000, 0111100, 0011100, 0011110, 0001110, 0001111, 0000111, the vector of discrete states completes one revolution in a converter period with a pitch of 25.71 electrical degree and „forms“ a space-time vector of continuous rotation for the first harmonic with an amplitude of 0.637. Converter frequency f with 14-step switching corresponds to the frequency of continuous rotation of the vector ($\bar{\omega} = 2pf$).

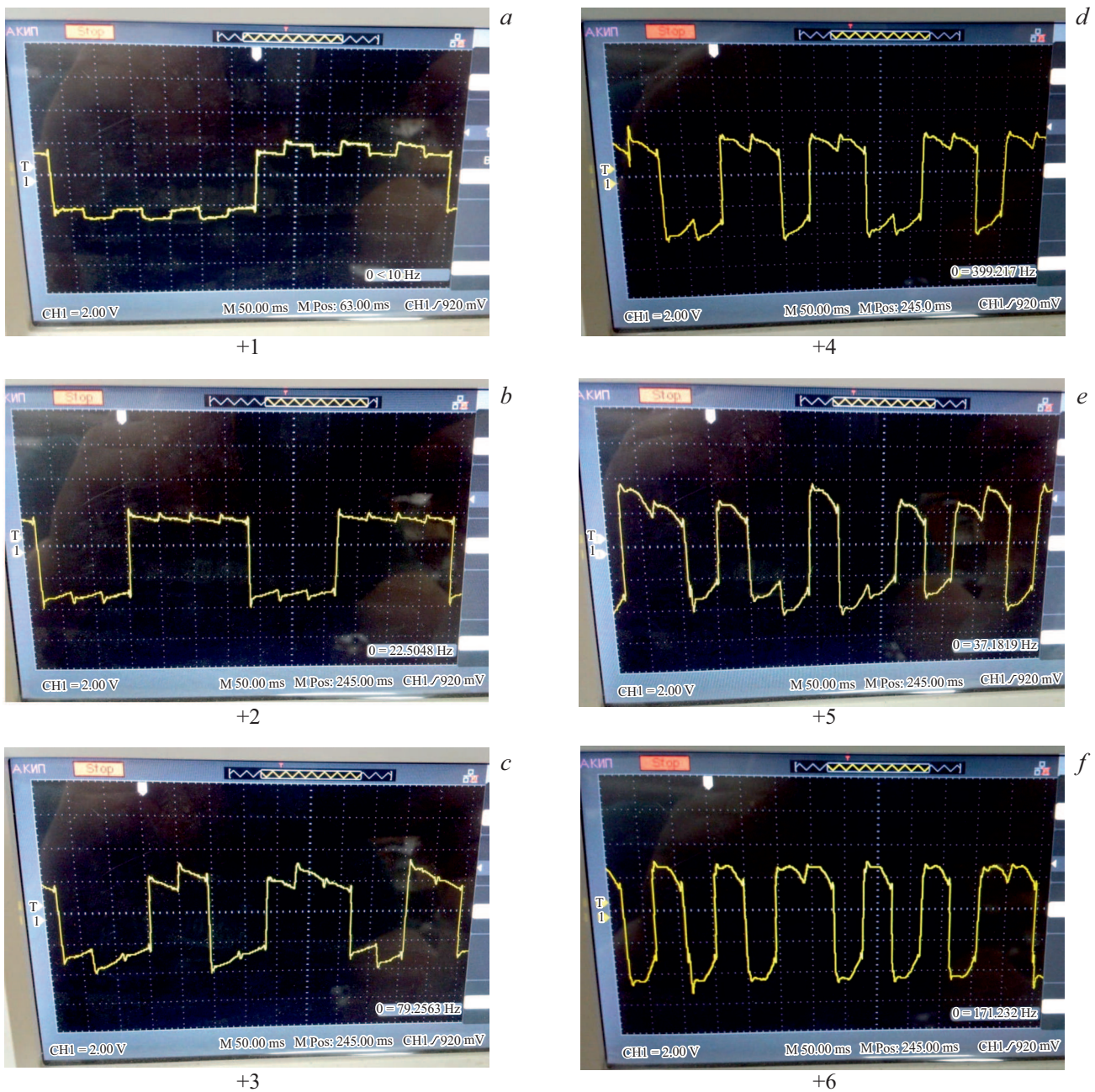

Figure 4. Phase voltage shapes corresponding to six combinations of version 1.

5.2. Combination 5 of the sample of version 1

With 14-step switching in the following sequence of logical states:

1000111, 1110000, 0011110, 1000011, 1111000, 0001110, 1100011, 0111000, 0001111, 1100001, 0111100, 0000111, 1110001, 0011100,

the vector of discrete states completes five revolutions in a converter period with a pitch of 525.71 electrical degree. This sequence of logical states „forms“ a space-time vector of continuous rotation for the fifth harmonic. The frequency of vector rotation is 5 times higher than the converter

frequency ($\bar{\omega} = 5 \cdot 2\pi f$). The number of key switchings in a period also increases by a factor of 5: $5 \cdot 14 = 70$.

The phase voltage is identical in shape to the one in version 9, but the time sequence of phases in this algorithm is ACEGBDF.

The algorithm (sequence of logical states of the converter) implementing the time sequence of phases ACEGBDF and enabling the generation of phase voltage with an enhanced fifth harmonic (Fig. 3, *i*) is a „fifth-harmonic algorithm“. The frequency of continuous rotation of the resultant voltage vector is 5 times higher than the converter frequency. The magnitude of the resultant

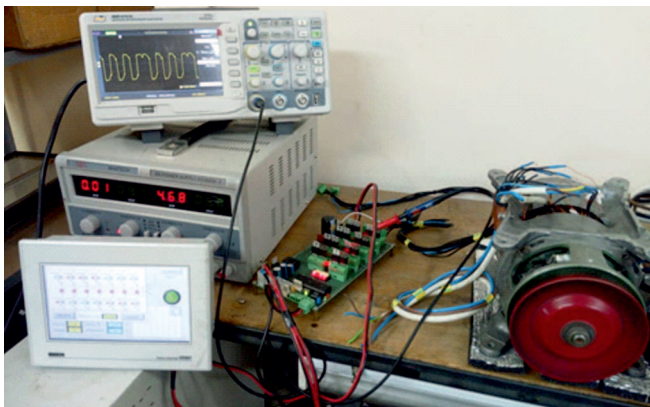

Figure 5. Test stand for the examination of algorithms of space-vector modulation of multiphase motors.

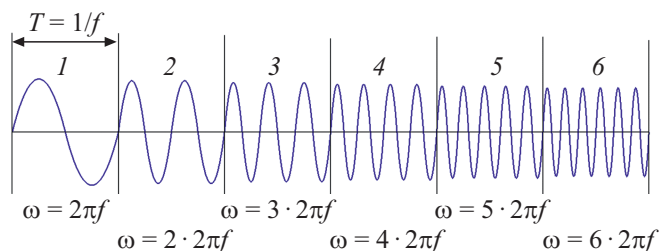

Figure 6. One converter frequency and 6 rates of rotation of the voltage vector.

vector of discrete states in combination 5 is the same as the magnitude of the resultant vector of discrete states in combination 1. The fifth-harmonic amplitude of the sine curve (Fig. 3, *i*), or the magnitude of the vector of continuous rotation, is 0.555 and differs from the first-harmonic amplitude of the sine curve (Fig. 3, *a*), which is equal to 0.637.

Similar reasoning holds true for six indicated combinations of logical states. This is illustrated by Fig. 6, where $T = 1/f$ is the converter period.

It follows from Fig. 6 that the resultant vector of continuous rotation of the seven-phase symmetrical winding has 6 rates (in the general case, $(m-1)$ rotation rates for an odd number of phases) of rotation at one converter frequency. For example, five- and eleven-phase windings have 4 and 10 rotation rates. A motor operates at the corresponding harmonics of the phase voltage generated by the corresponding algorithms (sequences of logical states of the converter).

It should be noted that a cardinality of 126 of the mathematical set of logical states corresponds to the converter switching mode with seven keys. Considering that the symmetrical seven-phase voltage may be generated by „chords“ of, e.g., six keys (only six phases of the motor are constantly active in this mode), the cardinality of the set is significantly higher than 126. The test stand in Fig. 5 is an efficient instrument for experimental studies into

space-vector modulation in different modes of operation of multiphase systems.

Findings

1. The cardinality of the mathematical set of logical states of the converter and the possible number of control algorithms implementing space-vector modulation upon generation of symmetrical voltage increases with the number of phases.

2. A seven-phase converter with space-vector modulation may generate symmetrical seven-phase voltage with nine shapes of phase voltage. Each shape of phase voltage corresponds to a certain vector space of generalized vectors of discrete states.

3. Each of the nine vector spaces has 6 combinations of sequences of vectors of discrete states, and each of the six combinations forms the resultant voltage vector of continuous rotation at a specific harmonic.

Conclusion

Using elements of set theory, combinatorics, Fourier series expansion, and vector analysis, we examined the control algorithms of a seven-phase converter implementing space-vector modulation of voltage of a seven-phase motor regarded as an alternative to three-phase motor in modern electric traction. The scientific novelty of the study lies in the fact that the set of active logical states of the seven-phase converter (the cardinality of this mathematical set is 126) may be divided into 9 subsets. Each subset generates symmetrical seven-phase voltage with a certain shape of phase voltage. Each shape of phase voltage corresponds to a certain vector space of discrete states, which consists of 14 vectors. The interchange sequence of these vectors has 6 combinations. The obtained results were verified using a specialized test stand for experimental research into space vector modulation of voltage of a seven-phase motor. The presented data may be used in the construction of electric traction based on a seven-phase motor.

Conflict of interest

The authors declare that they have no conflict of interest.

References

- [1] *Global EV Outlook: Understanding the Electric Vehicle Landscape to 2020*, Apr. 2013. [Online] Available: https://www.ourenergypolicy.org/wp-content/uploads/2013/09/GlobalEVO Outlook_2013.pdf
- [2] V.S. Tomasov, A.A. Usol'tsev, D.A. Vertegel, K.M. Denisov, *Nauchno-Tekh. Vestn. Inf. Tekhnol., Mekh. i Opt.*, **19** (2), 359 (2019). DOI: 10.17586/2226-1494-2019-19-2-359-368.
- [3] A.E. Kozyaruk, *Elektrotehnika*, **3**, 33 (2019) (in Russian).

- [4] Y.S. Zagoskin. *Adaptive Control System for Semiconductor Frequency Converters*. Proceed. 2020 IEEE Conf. Rus. Young Researchers in Electrical and Electronic Engineering EIConRus. 2020. P. 960.
- [5] *Elektrovoz gruzovoy postoyannogo toka 2ES10 (Granit) s asinkhronnymi tyagovymi elektrodvigatelyami. Rukovodstvo po ekspluatatsii* (Izd. Konstr.-Issled. Tsentra OAO STM, 2009) (in Russian).
- [6] H. Guzman, M. Bermúdez, C. Martín, F. Barrero, M.J. Durán. *Application of DSP in Power Conversion Systems — A Practical Approach for Multiphase Drives*, Ch. 6 in *Applications of Digital Signal Processing through Practical Approach*, ed. by S. Radhakrishnan (2015). DOI: 10.5772/59529
- [7] A. Gonzalez-Prieto, J.J. Aciego, I. Gonzalez-Prieto, M.J. Duran. *Electronics (Switzerland)*, **9** (6), 938 (2020). DOI: 10.3390/electronics9060938
- [8] A.N. Golubev, S.V. Ignatenko, *Elektrotehnika*, **6**, 28 (2000) (in Russian).
- [9] V.M. Tereshkin, D.A. Grishin, I.I. Balgazin, V.V. Tereshkin. *IEEE 2020 Intern. Conf. on Electrotechnical Complexes and Systems (ICOECS)*, 383 (2020). DOI: 10.1109/ICOECS50468.2020.9278415
- [10] V.M. Tereshkin, D.A. Grishin, I.A. Makulov, *J. Min. Inst.*, **240**, 678 (2019). DOI: 10.31897/PMI.2019.6.678