

Investigation of the emission spectrum of a fast capillary discharge in the „water window“ region

© A.A. Samokhvalov,^{1,2} K.A. Sergushichev,² S.I. Eliseev,^{2,3} T.P. Bronzov,² E.P. Bolshakov,²
D.V. Getman,² A.A. Smirnov²

¹ ITMO University, St. Petersburg, Russia; Laboratory named after V.A. Burtsev,
197101 St. Petersburg, Russia

² Laboratory them. V.A. Burtseva,
197022 St. Petersburg, Russia

³ St. Petersburg State University,
199034 St. Petersburg, Russia
e-mail: samokhvalov.itmo@gmail.com

Received March 31, 2023

Revised March 31, 2023

Accepted March 31, 2023

The results of experiments on the generation of soft X-ray pulses in the „water window“ region performed on a compact gas-discharge source are presented. The parameters of the radiation source were optimized based on the condition of reducing the intensity of capillary wall ablation and obtaining the maximum intensity of the helium-like nitrogen ion N VI —2.88 nm. The obtained results can be used in the development of a microscope for the tasks of cell microscopy with nanometer resolution.

Keywords: Capillary plasma, soft X-ray, „water window“, ablation, emission spectroscopy.

DOI: 10.61011/TP.2023.07.56621.64-23

Introduction

The 2.3–4.4 nm wavelength range (the so-called „water window“) is unique in that water is partially transparent within it, while the other substances and compounds are highly absorbing at the corresponding emission wavelengths. This provides an opportunity to obtain a natural contrast between, e.g., carbon- or nitrogen-containing compounds and water, offering ample opportunities for microscopic and tomographic examination of live and prepared (frozen) cell cultures and various nano- and bioobjects. The resolution capability of this microscopy technique was found to be as high as ~10 nm in studies of different cell biocultures [1]. However, synchrotron radiation sources are needed in such studies [2]. This is the key factor limiting the application of microscopy within the „water window“ in biomedical research and the reason why most researchers have never even heard of this method.

A number of attempts at constructing compact sources for this spectral range have been made in the last 20 years. Experiments with a capillary discharge (Z-pinch) in nitrogen rank among the most successful of them [3]. The emission of a capillary discharge is highly directional: the typical divergence of Z-pinch emission is 5–30 mrad [4,5]. At the same time, an intense helium-like nitrogen N VI line at 2.88 nm ($1s^2-1s2p$), which may be isolated with the use of special thin-film filters [6], is observed in the course of a discharge in nitrogen in the spectrum of capillary plasma. This provides an opportunity to produce directional and quasi-monochromatic radiation that is needed for microscopy in the „water window“ In addition, these factors

enable the application of diffraction optics (a Fresnel zone plate, which has long been used at synchrotron sources and the fabrication procedure of which has been refined significantly over the last years).

Soft X-ray radiation sources based on laser plasma are also evolving rapidly. A pulsed gas jet supplied via a nozzle is used as a target in such sources [7]. Among their advantages are a high spectral radiance and the lack of ablation products in a vacuum system. At the same time, special multilayer mirrors, the efficiency of which within the „water window“ reaches ~5% [8], are needed to transport laser plasma radiation. Their fabrication is a separate labor-intensive technological task. In addition, the cost of laser sources operating with a pulse repetition rate in excess of 20 Hz at a required pulse energy (more than 0.5 J) remains high. It is clear that both types of sources have their specific features; therefore, extensive studies are currently ongoing in these fields.

It is evident that a number of experiments focused on optimization of geometry of the discharge region, the working gas pressure, and other parameters need to be carried out in order to construct efficient gas-discharge sources. In the present study, the parameters of a compact radiation source with an operating wavelength of 2.88 nm based on a nanosecond capillary discharge are examined and optimized.

1. Experimental setup

The design of a compact soft X-ray radiation (SXR) source based on a capillary discharge and the measurement

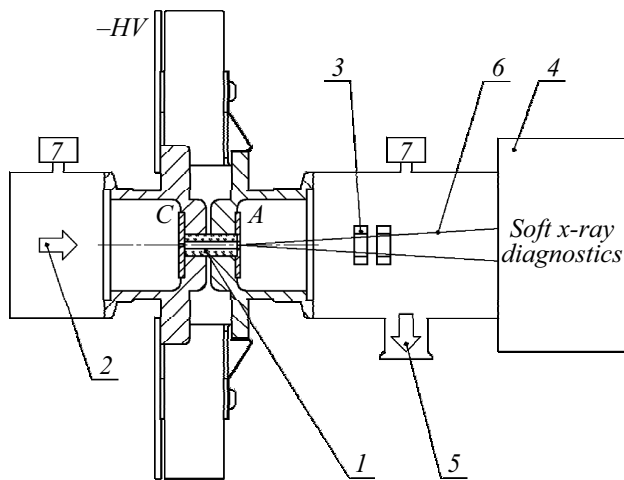

Figure 1. Diagram of the experimental setup: 1 — capillary, 2 — gas flow direction, 3 — thin-film filters, 4 — photodiode and spectrometer location, 5 — direction of gas evacuation with a turbomolecular pump, 6 — direction of a soft X-ray beam, 7 — location of pressure sensors, C — cathode, and A — anode.

technique were detailed in our previous study [9], where the problem of „contamination“ of the plasma spectrum by spectral lines of elements present in the capillary structure material was solved partially by reducing the voltage pulse length and adjusting the working gas pressure. However, the capillary used in the present study is ceramic (made of Si_3N_4), since silicon ions have no lines in the region close to the „water window“ and this material offers higher thermal and mechanical strength values than borosilicate glass. The inner diameter of the capillary was 1.5 mm, and its length was 20 mm.

A FDUK-1 silicon photodiode (produced at the Ioffe Institute) with an active region 1 mm^2 in size was used to examine radiation parameters. This photodiode allowed us to record the time profile of a radiation pulse with a resolution no worse than $\sim 1\text{ ns}$. Its rated sensitivity within the 2–10 nm wavelength range is $\sim 0.26\text{ A/W}$. Two freely suspended thin-film filters were positioned in front of the photodiode. The first was fabricated from aluminum, and the second was made of Ti–C; their thicknesses were $\sim 200\text{ nm}$. A permanent magnet was installed beyond the anode of the capillary assembly to deflect an electron beam. The filters attenuated visible radiation by a factor of 10^6 , and their combination allowed us to isolate the needed radiation range from 2.5 to 5 nm.

Capillary plasma spectra were recorded using a GIS-2 grazing incidence spectrometer with a 1200 mm^{-1} diffraction grating, and a Toshiba 1304 CCD linear sensor with a phosphor applied to it was used as a detector. Spectral resolution $\lambda/\Delta\lambda$ of the spectrometer was ~ 200 .

Current pulses were measured by a Rogowski coil, and a high-voltage divider was used to measure voltage pulses. All signals were recorded with a four-channel Tektronix DPO-7104C oscilloscope with a bandwidth of 1 GHz and averaged over 20 pulses; the spectra were also

averaged over 20 discharges. The voltage pulse amplitude in experiments was as high as 27 kV, the rate of current rise was $\sim 2 \cdot 10^{12}\text{ A/s}$ at a current amplitude of 23 kA, the energy stored in the surge capacitance of the source was 5 J, and the operating frequency of the source was 300 Hz. Only high-purity (99.99%) nitrogen was used as a working gas in the discussed experiments.

2. Experimental findings

Figure 2 presents the typical oscilloscope records of a current pulse, a radiation pulse, and a voltage pulse corresponding to a discharge in nitrogen.

The vertical dashed line in Fig. 2 denotes the moment of cathode–anode gap breakdown, which is characterized by a clear cut-off of the trailing edge of the voltage pulse and the simultaneous emergence of current and radiation pulses. A similar dynamics of electrophysical parameters has also been observed in the event of breakdown in CO_2 in our study [9]. It is notable that the radiation pulse features two pronounced maxima shifted by $\sim 20\text{ ns}$ from the first two positive current half-waves, and the amplitude of the first maximum is higher. These features of capillary plasma emission are dictated by hydrodynamic pinching processes at high currents flowing via a plasma filament. However, the dynamics of electrophysical parameters remained essentially independent on the working gas pressure, while the intensity of soft X-ray radiation varied significantly with it. Therefore, emission spectra of capillary plasma (see Fig. 3, where typical emission spectra of a capillary discharge in nitrogen recorded under different working gas pressures are presented) were analyzed to obtain a qualitative understanding of the studied phenomena.

Lines of helium-like N VI (2.88 nm, $1s^2-1s2p$) and hydrogen-like nitrogen N VII (2.48 nm, $1s-2p$) are seen

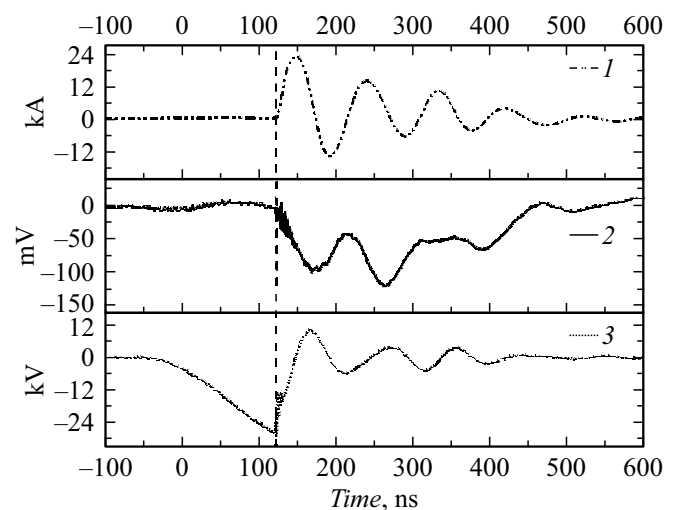

Figure 2. Typical oscilloscope records upon a discharge in pure nitrogen under a working pressure of 1.5 Torr: current pulse (1), radiation pulse transmitted through the combination of Al and Ti–C filters (2), and voltage pulse (3).

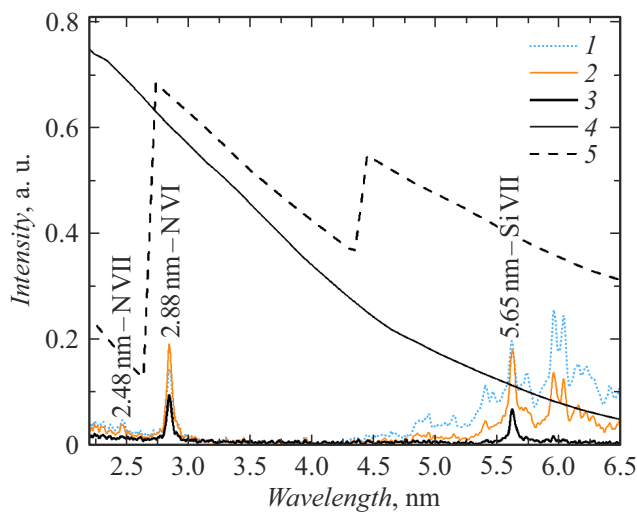

Figure 3. Emission spectra of capillary nitrogen plasma recorded under different pressures: 1 — 2.5, 2 — 3, and 3 — 3.5 Torr. 4 — Transmission spectrum of the aluminum filter; 5 — transmission spectrum of the titanium filter.

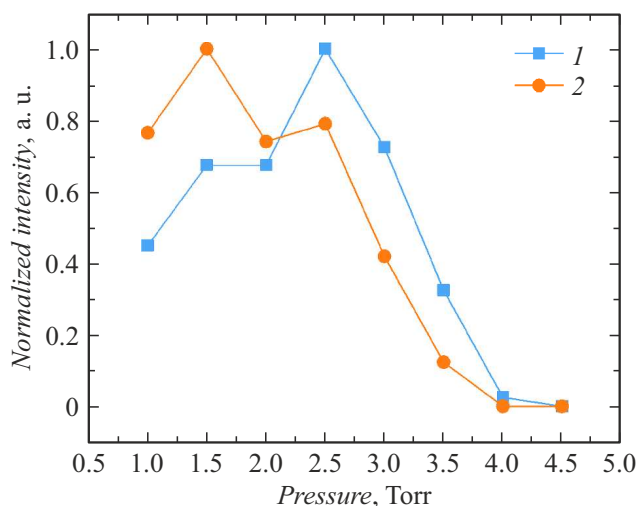

Figure 4. Dependences of the intensities of spectral lines N VI — 2.88 nm (1) and Si VII — 5.62 nm (2) on the gas pressure.

in Fig. 3. At the same time, silicon ions Si VII emerged in the spectrum due to the interaction of plasma with the capillary wall and its subsequent ablation, but no lines were observed in the 3–4.5 nm region. The transmission spectra of filters, which are also shown in Fig. 3, suggest that the combination of Al and Ti filters blocks silicon lines, allowing one to isolate the nitrogen N VI line at 2.88 nm. It can be seen that even a slight variation of the gas pressure induced a marked change in the emission spectrum: silicon lines vanished under a pressure of 3.5 Torr, and the intensity of the nitrogen N VI line at a wavelength of 2.88 nm was significantly higher than the intensity of the silicon line at 5.65 nm. In general, the intensity of both nitrogen and silicon lines decreased rapidly with increasing pressure.

Figure 4 shows the normalized integral dependences of spectral lines on the gas pressure.

It can be seen that the dependence of the spectral line intensity on pressure is extremal in nature with silicon and nitrogen lines reaching their maximum intensities at different pressures. This allows one to establish such conditions in which the wall ablation is minimized while the nitrogen line remains fairly intense. This is exactly what is needed for microscopy in the „water window“ (i.e., for production of monochromatic radiation).

Conclusion

The results of experiments with a compact gas-discharge SXR source, which used pure nitrogen as a working gas, were reported. The possibility to produce a single spectral line of a helium-like nitrogen ion at a wavelength of 2.88 nm, which is positioned within the „water window“, was demonstrated. The source generates SXR pulses with a repetition rate up to 300 Hz. In subsequent studies, we plan to raise the pulse repetition rate by modifying the high-voltage generator.

The obtained results may find application in the design of a microscope and a tomograph for the examination of cell cultures and other nano- and bioobjects in the transmission mode.

Funding

This study was supported by a grant from the Russian Science Foundation (project № 21-79-10110).

Conflict of interest

The authors declare that they have no conflict of interest.

References

- [1] M. Kördel, A. Dehlinger, C. Seim, U. Vogt, E. Fogelqvist, J.A. Sellberg, H. Stiel, H.M. Hertz. *Optica*, **7** (6), 658 (2020). DOI: 10.1364/OPTICA.393014
- [2] V. Loconte, J.-H. Chen, M. Cortese, A. Ekman, M.A. Le Gros, C. Larabell, R. Bartschlagler, V. Weinhardt. *Cell Rep. Meth.*, **1** (7), 100117 (2022). DOI: 10.1016/j.crmeth.2021.100117
- [3] M.P. Valdivia, E.S. Wyndham, M. Favre, J.C. Valenzuela, H. Chuaqui, H. Bhuyan. *Plasma Sourc. Sci. Technol.*, **21** (2), 025011 (2012). DOI: 10.1088/0963-0252/21/2/025011
- [4] E.S. Wyndham, M. Favre, M.P. Valdivia, J.C. Valenzuela, H. Chuaqui, H. Bhuyan. *Rev. Sci. Instrum.*, **81** (9) (2010). DOI: 10.1063/1.3482070
- [5] M.F. Nawaz, M. Nevrkla, A. Jancarek, A. Torrisi, T. Parkman, J. Turnova, L. Stolcova, M. Vrbova, J. Limpouch, L. Pina, P. Wachulak. *JINST*, **11**, P07002 (2016). DOI: 10.1088/1748-0221/11/07/P07002
- [6] N.I. Chkhalo, M.N. Drozdov, S.A. Gusev, E.B. Klunokov, A.Y. Lopatin, V.I. Luchin. *Proc. SPIE*, **8076**, 807600 (2011). DOI: 10.1117/12.886781

- [7] V.E. Guseva, A.N. Nechay, A.A. Perekalov, N.N. Salashchenko, N.I. Chkhalo. *Tech. Phys.*, **67** (8), 1002 (2022).
DOI: 10.21883/TP.2022.08.54563.72-22
- [8] E. Fogelqvist, M. Kördel, V. Carannante, B. Önfelt, H.M. Hertz. *Sci. Rep.*, **7** (1), 13433 (2017).
DOI: 10.1038/s41598-017-13538-2
- [9] A.A. Samokhvalov, K.A. Sergushichev, S.I. Eliseev, A.A. Smirnov, T.P. Bronzov, D.V. Getman, E.P. Bolshakov, M.V. Timshina, V.A. Burtsev. *JINST*, **17**, P06002 (2022).
DOI: 10.1088/1748-0221/17/06/P06002

Translated by D.Safin